



Parts Manual

Mfg. No: 020224-1
2,700 PSI

Model Components	Page
Main Unit.....	4
Pump.....	6
Torque Specification Chart.....	8

Not For
Reproduction

Main Unit

Note: Unless noted otherwise, use the standard torque specifications

Mfg. No: 020224-1

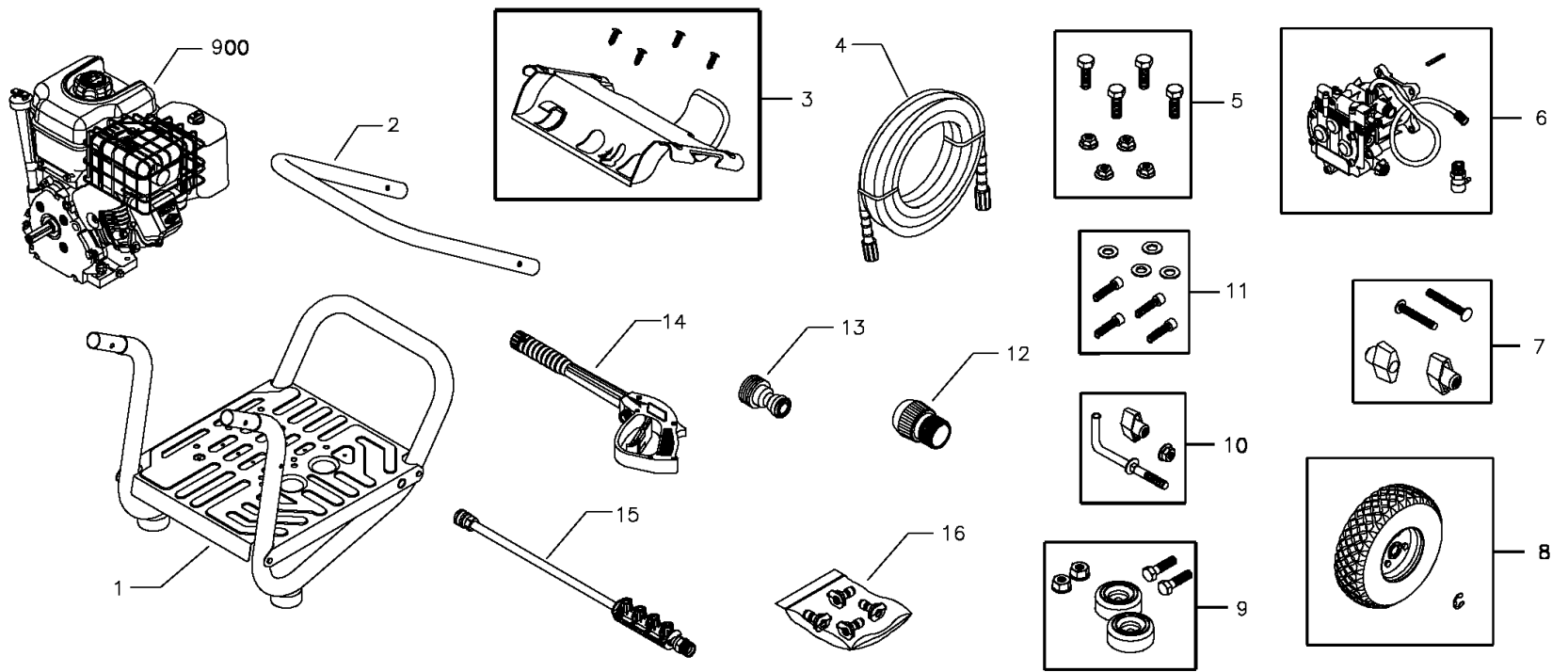

Not For
Reproduction

Main Unit

REF NO	PART NO	QTY	DESCRIPTION
1	198732GS		ASSY, Base
2	M194567GS		HANDLE
3	200170GS		ASSY, Billboard w/Decals & Clips
	195964GS		Clips, Tree
4	196006GS		HOSE
5	192318GS		KIT, Engine Mounting Hardware
6	198347GS		ASSY, Pump
	23139DGS		Key
	94298GS		Valve, Thermal Relief
7	B2203GS		KIT, Handle Fastening
8	194509GS		KIT, Wheel
	191265GS		E-Ring
9	192310GS		KIT, Vibration Mount
10	193819GS		KIT, Hook
11	192131GS		KIT, Pump Mounting Hardware
12	96016GS		QUICK CONNECT, Female, Plastic
13	95456GS		QUICK CONNECT, Male
14	193482GS		GUN
15	192198GS		EXTENSION, w/Nozzle Holder
16	196902GS		KIT, Nozzle
	198841GS		Nozzle, QC, Plastic, Soap
	195983WGS		Nozzle, QC, Red
	195983XGS		NOZZLE-QC YELLOW
	195983ZGS		Nozzle, QC White
900	-----		ENGINE -Contact Engine Manufacturer
	203763GS		MANUAL, Operator's -Not Illustrated
	MS3431		MANUAL, Engine -Not Illustrated
	191267SGS		AXLE -Not Illustrated
	192014GS		FITTING, 1/2" -Not Illustrated
	192015GS		FITTING, 3/4" -Not Illustrated
	200171GS		KIT, INT'L Tag Warning -Not Illustrated
	6048		KIT-O-Ring -Not Illustrated
	6039		PUMP SAVER -Optional Accessory

Pump

Note: Unless noted otherwise, use the standard torque specifications

Mfg. No: 020224-1

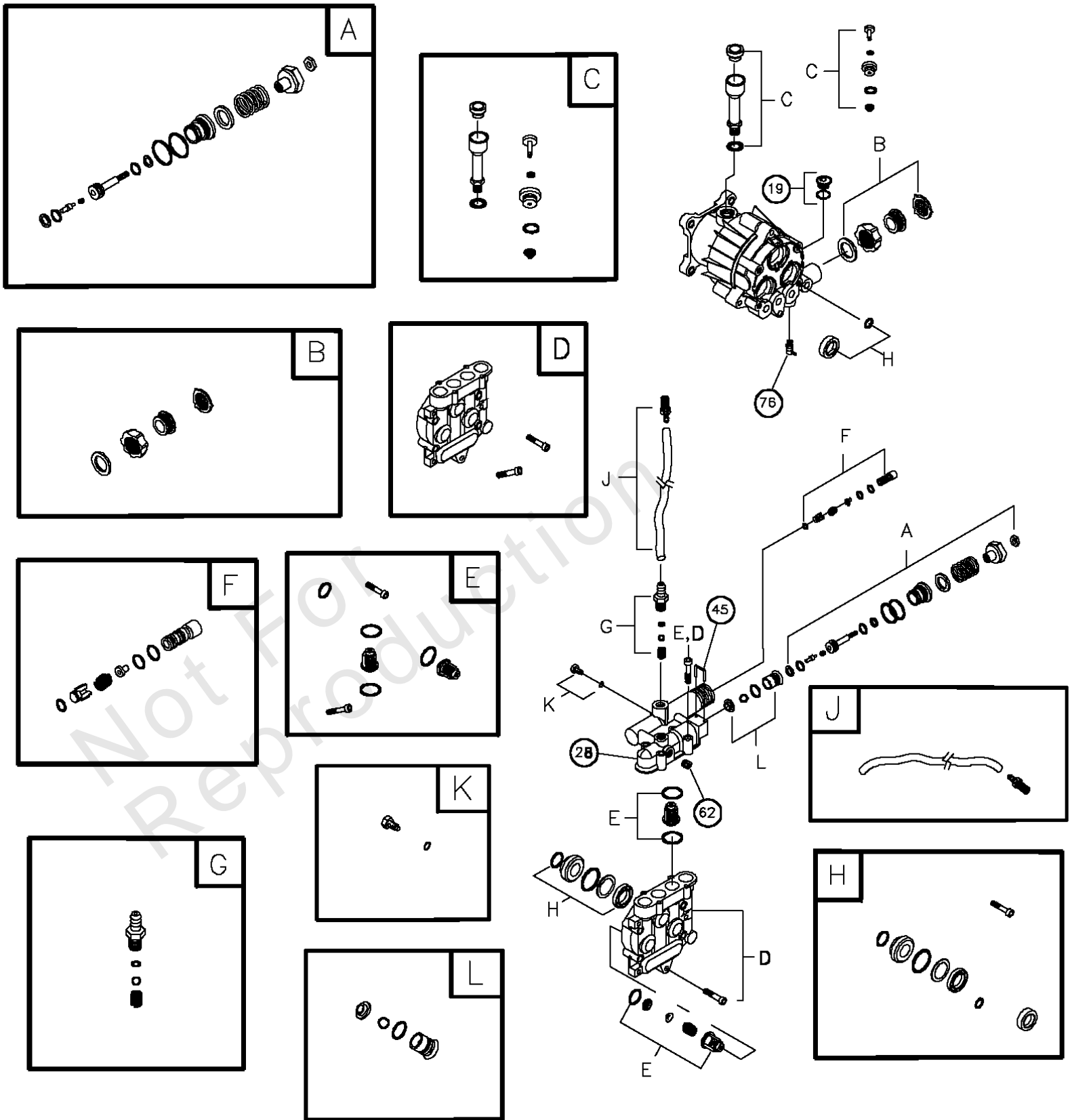

Pump

REF NO	PART NO	QTY	DESCRIPTION
19	190571GS		CAP, Oil
28	198102GS		MANIFOLD
45	190578GS		PIN
62	190581GS		CAP, 1/8
76	194298GS		VALVE, Thermal Relief
A	190594GS		KIT, Unloader -Service kits include all parts shown within the box.
B	190670GS		KIT, Water Inlet -Service kits include all parts shown within the box.
C	190669GS		KIT, Breather Tube -Service kits include all parts shown within the box.
D	193808GS		KIT, Head Brass -Service kits include all parts shown within the box.
E	193806GS		KIT, Check Valves -Service kits include all parts shown within the box.
F	190592GS		KIT, Inlet Check -Service kits include all parts shown within the box.
G	190593GS		KIT, Chemical Injection -Service kits include all parts shown within the box.
H	193807GS		KIT, Seal Set -Service kits include all parts shown within the box.
J	189971GS		KIT, Chemical Hose -Service kits include all parts shown within the box.
K	193971GS		KIT, Pipe Fitting -Service kits include all parts shown within the box.
L	193972GS		KIT, Unloader Seat -Service kits include all parts shown within the box.
	B2384GS		FILTER, Inlet -Not Illustrated
	190586GS		OIL BOTTLE -Not Illustrated
	186452GS		FILTER, Inlet, Bag of 10 -Not Illustrated

Hardware Identification & Torque Specifications

Torque Specification Chart								
FOR STANDARD METRIC MACHINE HARDWARE (Tolerance ± 20%)								
Property Class	5.6		8.8		10.9		12.9	
	Class 5.6		Class 8.8		Class 10.9		Class 12.9	
Size Of Hardware	in/lbs	Nm.	in/lbs	Nm.	in/lbs	Nm.	in/lbs	Nm.
	ft/lbs		ft/lbs		ft/lbs		ft/lbs	
M3	5.88	.56	13.44	1.28	19.2	1.80	22.92	2.15
M4	13.44	1.28	30.72	2.90	43.44	4.10	52.56	4.95
M5	26.4	2.50	60.96	5.75	5.97	8.10	7.15	9.7
M6	44.64	4.3	7.3	9.9	10.3	14	12.1	16.5
M7	5.2	7.1	12.1	16.5	16.9	23	19.9	27
M8	7.7	10.5	17.7	24	25	34	29	40
M10	15	21	35	48	50	67	59	81
M12	26	36	61	83	86.2	117	103	140
M14	42	58	101	132	136	185	162	220
M16	64	88	147	200	210	285	250	340
M18	89	121	202	275	287	390	346	470
M20	126	171	290	390	405	550	486	660
M22	169	230	390	530	559	745	656	890
M24	217	295	497	375	708	960	840	1140
M27	320	435	733	995	1032	1400	1239	1680
M30	435	590	995	1350	1401	1900	1681	2280
M33	590	800	1349	1830	1902	2580	2278	3090
M36	759	1030	1740	2360	2441	3310	2935	3980
M39	988	1340	2249	3050	3163	4290	3798	5150

Torque Specification Chart						
FOR STANDARD MACHINE HARDWARE (Tolerance ± 20%)						
Hardware Grade	No Marks		SAE Grade 5		SAE Grade 8	
	SAE Grade 2		SAE Grade 5		SAE Grade 8	
Size Of Hardware	in/lbs	Nm.	in/lbs	Nm.	in/lbs	Nm.
	ft/lbs		ft/lbs		ft/lbs	
8-32	19	2.1	30	3.4	41	4.6
8-36	20	2.3	31	3.5	43	4.9
10-24	27	3.1	43	4.9	60	6.8
10-32	31	3.5	49	5.5	68	7.7
1/4-20	66	7.6	8	10.9	12	16.3
1/4-28	76	8.6	10	13.6	14	19.0
5/16-18	11	15.0	17	23.1	25	34.0
5/16-24	12	16.3	19	25.8	29	34.0
3/8-16	20	27.2	30	40.8	45	61.2
3/8-24	23	31.3	35	47.6	50	68.0
7/16-14	30	40.8	50	68.0	70	95.2
7/16-20	35	47.6	55	74.8	80	108.8
1/2-13	50	68.0	75	102.0	110	149.6
1/2-20	55	74.8	90	122.4	120	163.2
9/16-12	65	88.4	110	149.6	150	204.0
9/16-18	75	102.0	120	163.2	170	231.2
5/8-11	90	122.4	150	204.0	220	299.2
5/8-18	100	136	180	244.8	240	326.4
3/4-10	160	217.6	260	353.6	386	525.0
3/4-16	180	244.8	300	408.0	420	571.2
7/8-9	140	190.4	400	544.0	600	816.0
7/8-14	155	210.8	440	598.4	660	897.6
1-8	220	299.2	580	788.8	900	1,244.0
1-12	240	326.4	640	870.4	1,000	1,360.0

The guides and ruler furnished below are designed to help you select the appropriate hardware.



Nut, M8

Thread Diameter (mm)

Inside Diameter (in) Threads per inch

Nut, 1/2-16



Screw, M8- 1.25 x 25

Thread Diameter (mm) Distance between threads (mm) Body Length (mm)

Body Diameter Threads per inch Body Length (in)

Screw, 1/2- 16 x 2



Standard Hardware Sizing

When a washer or nut is identified as 1/2" (M8), this is the *Nominal size*, meaning the *inside diameter* is 1/2 inch (8mm metric thread diameter); if a second number is present it represents the *threads per inch* (distance between threads).

When bolt or capscrew is identified as 1/2 - 16 x 2" (M8 - 1.25 x 50), this means the *Nominal size*, or body diameter is 1/2 inch (8mm metric thread diameter), the second number, 16, represents the *threads per inch*, (*distance between threads*). The final number is the body length of the bolt or screw, 2 inches (50mm).

NOTES

- These torque values are to be used for all hardware excluding: locknuts, self-tapping screws, thread forming screws, sheet metal screws and socket head setscrews.
- Recommended seating torque values for locknuts:
 - for prevailing torque locknuts - use 65% of grade 5 torques.
 - for flange whizlock nuts and screws - use 135% of grade 5 torques.
- Unless otherwise noted on assembly drawings, all torque values must meet this specification.

Common Hardware Types

Hex Head Capscrew

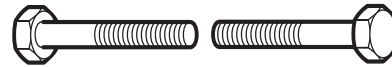

Washer



Carriage Bolt



Hex Nut

Wrench & Fastener Size Guide

1/4" Bolt or Nut Wrench—7/16"	5/16" Bolt or Nut Wrench—1/2"	3/8" Bolt or Nut Wrench—9/16"	7/16" Bolt or Nut Wrench (Bolt)—5/8" Wrench (Nut)—11/16"	1/2" Bolt or Nut Wrench—3/4"
M6 Bolt or Nut Wrench—10mm	M8 Bolt or Nut Wrench—13mm	M10 Bolt or Nut Wrench—17mm	M12 Bolt or Nut Wrench—19mm	M14 Bolt or Nut Wrench—22mm

